



Hoval MultiJet
Condensing oil fired boilers
from 14 to 26kW output.

Up to 40% energy savings!

KOOLFUEL®
energy for a future

Hoval

In the middle of Winter you can relax in the knowledge that your Hoval boiler is as reliable as it is efficient. The unique “Jet-Technology” system within the boiler optimises heat transfer which enables the combustion gases to condense, achieving maximum efficiency. For those who value the environment and want to keep running costs to a minimum, there is the Hoval MultiJet.

KOOLFUEL®
energy for a future

Hoval MultiJet. Offers great value and saves in many different ways.

Up to 40% less energy.



With the all new Jet technology system the Hoval MultiJet is truly a special design. There are many factors that make the Hoval MultiJet boiler a wise investment.

It saves energy: Revolutionary Jet technology increases the energy efficiency of the Hoval MultiJet compared to modern low temperature boilers by 11%. However, against a 20 year old boiler it can reduce the oil consumption by up to 40%. This probably makes the Hoval MultiJet the most energy saving oil-fired boiler in the world. The special design of the Hoval MultiJet reduces the burner starts which results in 20% less pollutant emissions. It also reduces thermal stresses on the combustion chamber.

It saves money: The modest extra cost of the MultiJet boiler is paid back within a short period due to the low operating costs. After this time the Hoval MultiJet saves you even more money year in and year out.

It saves space: A great advantage of the Hoval MultiJet is its slim design which requires only a small footprint area. With a maximum width of only 520mm, a depth of 950mm and a height of approx. 1900mm, a place can be found even in the smallest niche.

But, all of these savings do not compromise quality: The choice of materials and manufacturing process are of the usual Hoval high standards providing both durability and reliability.

Oil consumption (litres per year)

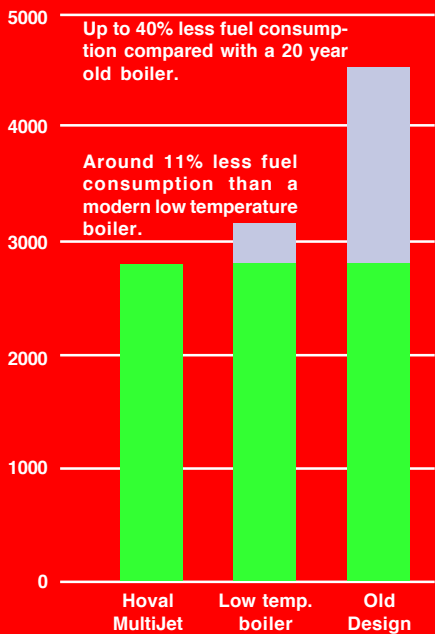

- **Maximum energy yield**
- **Low noise emission**
- **Simple hydraulic installation**
- **No minimum water flow rate**
- **No minimum return temperature**
- **No minimum boiler temperature**
- **Minimum footprint**
- **Application of plastic flue gas system**
- **Due to low flue gas temperature (<120°C)**
- **Flue gas diameter of only 80 mm**

The Hoval MultiJet challenges existing rules associated with oil fired installations. Increasing efficiency by unlocking the extra energy within the latent heat of the combustion gases. The Hoval MultiJet - oil fired condensing boiler.

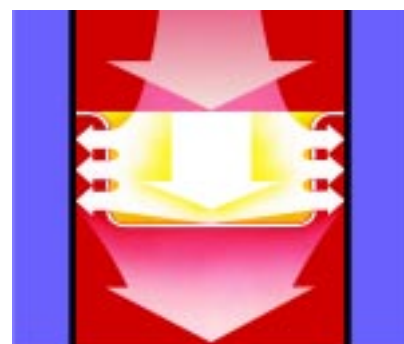
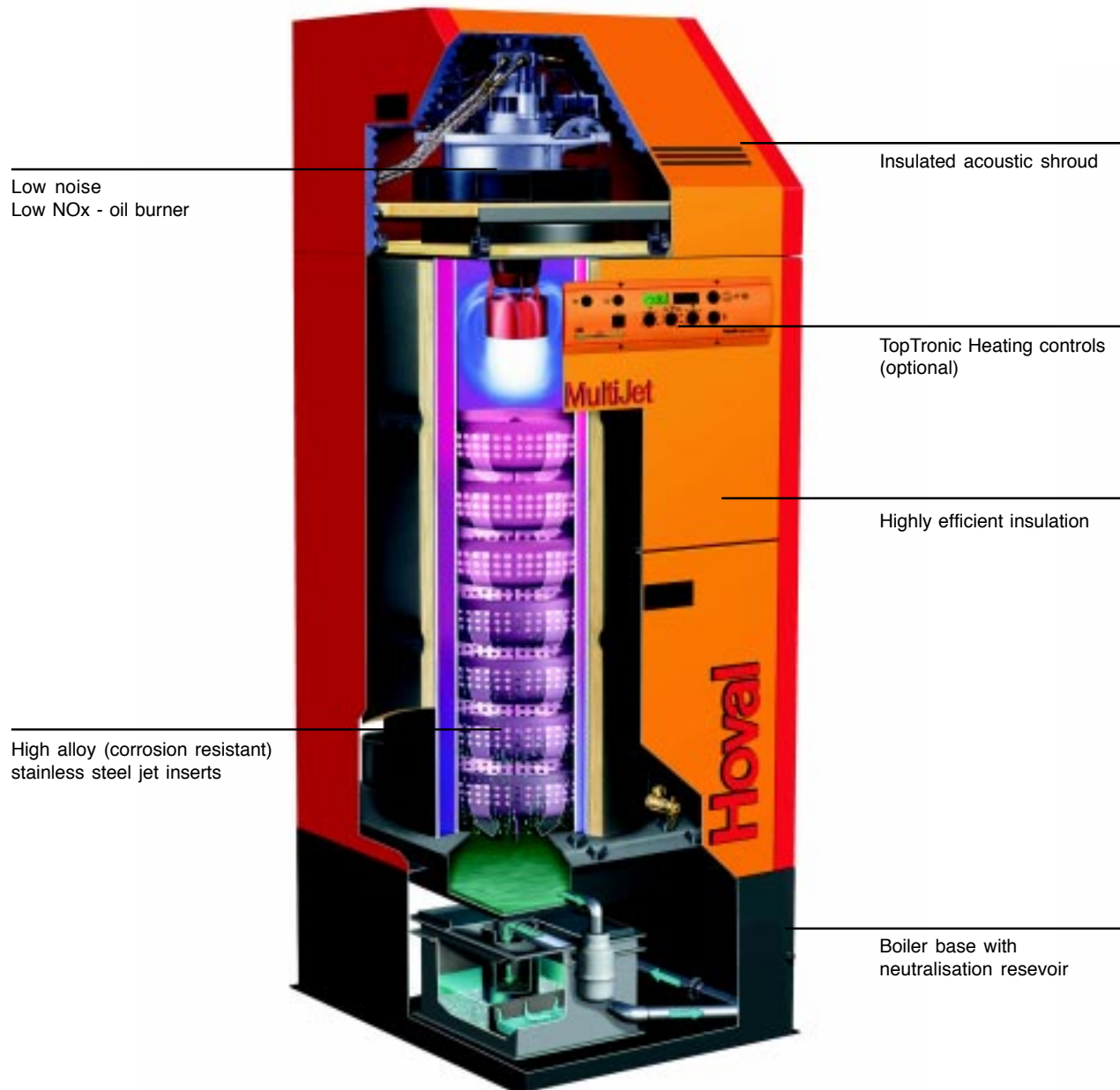

11% more energy gain. 20% lower emission of pollutants. Thanks to Jet-Technology. The benefits of condensing boilers are well proven in gas fired installations. But in oil fired installations, heat energy locked-up in the form of latent heat within the combustion gases are normally lost up the chimney. The Hoval MultiJet can extract this energy by condensing the combustion gases before they leave the boiler, thus making it more efficient than conventional oil fired boilers. Condensing on oil is achieved by a completely new designed heat exchanger – this utilizes “Jet-technology”.

The ideal solution for low-energy housing and refurbishment of existing buildings.

For low energy heating the Hoval MultiJet is a smart choice. With the Hoval MultiJet the heating costs are reduced by up to 40% compared with old heating systems. So by investing in a MultiJet boiler your annual heating bill will be considerably less in the future.



Further advantages such as space saving and simple connection to the existing power supply, makes the Hoval MultiJet the first choice when upgrading your old heating system.



Jet Technology. The Principle of Efficiency.

The hot gases fired down from the top of the combustion chamber, pass through an arrangement of approximately 70 holes around the outside edge of the Jet inserts. The hot gases are diverted at right angles through these holes at very high velocities. The combustion gases then hit the combustion chamber wall head-on

at very high speeds, this ensures a maximum rate of heat transfer. The heat contained in the flue gases, is converted into heating energy. There are a total of seven such “Jet-steps” one on top of another in cascade format which cool the combustion gases from 1200°C down to approximately 40°C.

Material Quality. Designed for Durability.

The material and manufacturing quality of the Hoval MultiJet are chosen solely for their durability. The parts of the boiler which are in close contact with the combustion gases are constructed from high alloy stainless steel.

This provides high protection against corrosion. This choice of high quality material, coupled with the best manufacturing processes continues the Hoval tradition.



Compact. Quickly installed. Low Noise.

The Hoval MultiJet not only saves space but also saves on installation time and costs. Connecting to your heating system is simple and the additional cost of back-end boiler protection arrangements are eliminated.

Besides the ease of installation and the compact exterior, the Hoval MultiJet boiler also boasts low noise emissions. Compared to conventional installations of similar performance the Hoval MultiJet delivers approximately 50%

less noise directly from the boiler and as much as 70% less noise emissions from the chimney.

Comprehensive range of standard flue components. Hoval offer a range of flue components to meet your requirements.

Technical Data			
Hoval MultiJet Type	16	20	25
Nominal heat output at 40/30°C	16.8kW	21.0kW	26.0kW
Net efficiency to DIN 4702 Part 8 at 40/30°C operation	104.0%	103.8%	103.4%
Minimum boiler return temperature	no lower limit		
Weight	107kg	185kg	200kg
Height/Width/Depth (mm)	1335/480/480	1730/520/920	1880/520/920

Technical Data

MultiJet

Type		(16)	(20)	(25)
• Rated heating capacity 80/60°C ¹	kW	16	20	25
• Rated heating capacity 40/30°C	kW	16,8	21	26
• Heat output range 80/60°C	kW	14-16	16-20	16-25
• Heat Input	kW	14,3-16,5	20,4	25,6
• Dimensions (with burner and acoustic shroud)	width	mm	480	520
	length	mm	480	920
	height	mm	1335	1730
• Maximum boiler operating temperature ²	°C	90	90	90
• Minimum boiler operating temperature	°C		No minimum	
• Minimum boiler return temperature	°C		No minimum	
• Minimum flue gas temperature at boiler	°C		No minimum	
• High temperature limit thermostat setting	°C	110	110	110
• Operating / test pressure	bar	3,0/4,5	3,0/4,5	3,0/4,5
• Boiler efficiency net	at 80/60°C	%	98,1	98,0
	at 40/30 °C	%	102,6	102,5
• Efficiency (according to DIN4702 part 8)	at 75/60 °C	%	101,3	101,1
	at 40/30 °C	%	104	103,8
• Standby losses qB at 70 °C	Watt	148	194	201
• Combustion gas resistance, 12,5% CO ₂ , 500 m above sea level (Tolerance ± 20%) ⁴	m bar	1,4	0,58	0,67
• Flue gas mass flow at full output 12,5% CO ₂ oil EL	kg/h	24,3	31	38,9
• Condensate rate at 40/30 °C	l/h	0,87	1,26	1,75
• Hydraulic resistance through the boiler ³	z-factor	4,5	3,4	3,4
• Hydraulic resistance with 10 K ΔT	m bar	8,5	9,9	15,6
• Hydraulic resistance with 20 K ΔT	m bar	2,1	2,51	3,9
• Water Flow rate with 10 K ΔT	m ³ / h	1,37	1,71	2,14
• Water Flow rate with 20 K ΔT	m ³ / h	0,69	0,86	1,07
• Boiler water content	litres	35	50	58
• Boiler gas content	m ³	0,024	0,076	0,088
• Insulation thickness	mm	80	80	80
• Weight (dry)	kg	107	185	200
• Transport weight	kg	85	160	175
• Noise levels with acoustic cover fitted				
- Heating noise ⁷	dB(A)	63	64 ⁵	64 ⁶
- Chimney noise ⁸	dB(A)	61	74 ⁵	74 ⁶
• Combustion chamber dimensions Ø-inside x Length	mm	ø189x310	ø295x408	ø295x420
• Combustion chamber volume	m ³	0,0087	0,027	0,028
• Delivery pressure at flue gas outlet	Pa	30	50 ⁵	50 ⁶

¹ kW = pollutant limits and flue gas losses in accordance with standard LRV 92 (boiler water temperature 80°C)

² Maximum setting on control thermostat 90°C

³ Hydraulic resistance of boiler in mbar = flow rate (m³/h)² x z factor

⁴ Data valid for Hoval oil boiler unit

⁵ Burner type GB 2020 (Flue gas system DN80)

⁶ Burner type GB 2025 (Flue gas system DN80)

⁷ Noise measured at a distance of 1m from boiler

⁸ Indicative noise measured at chimney terminal

$$\text{mbar} = (\text{m}^3 / \text{h})^2 \times z$$

$$\text{mbar} = \text{hydraulic resistance} \times \text{Flow rate}$$

Note: The sulphur content of the fuel oil used must be a maximum of 0.2% by weight.

Dimensional details

MultiJet 16

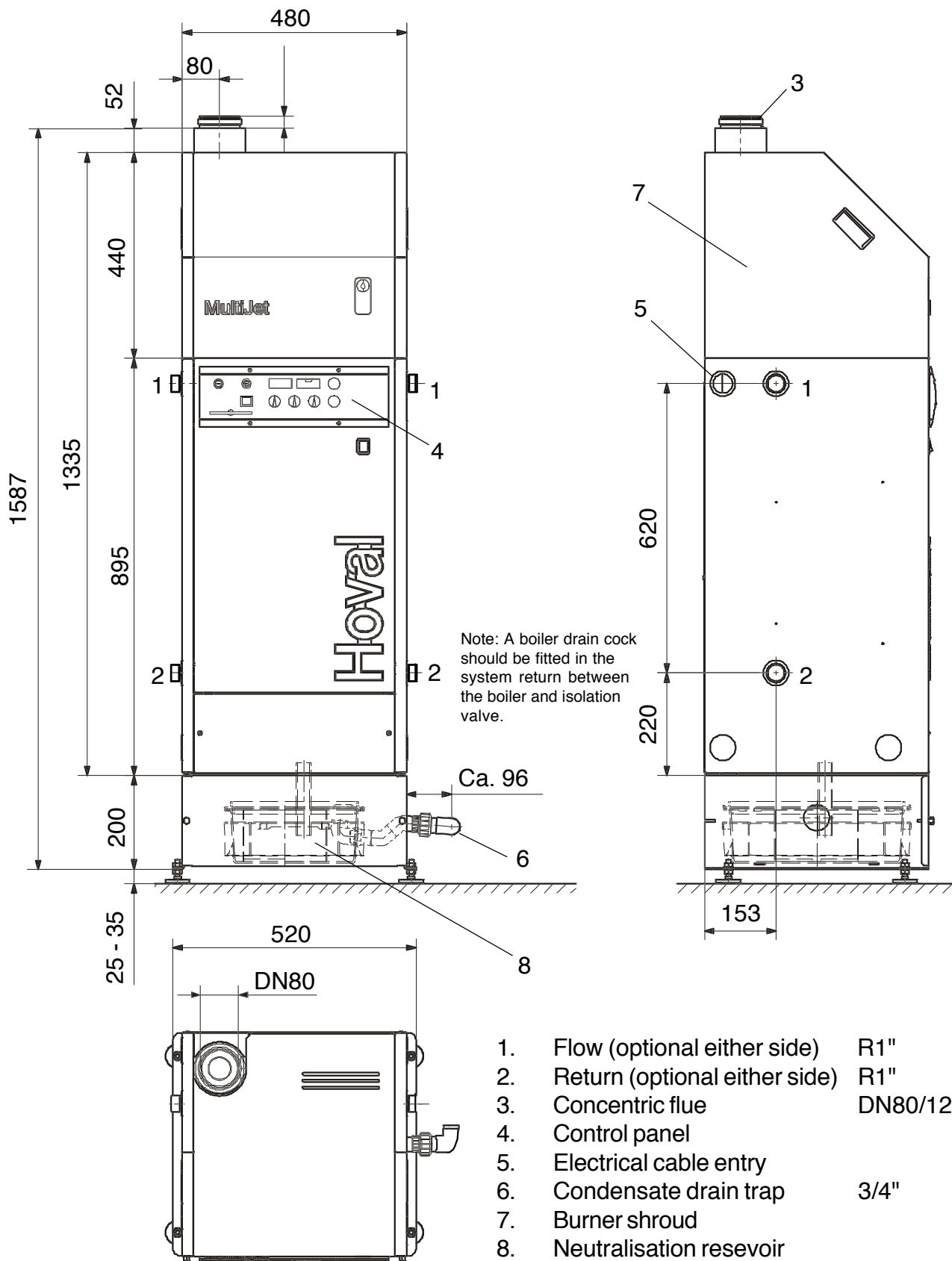

Dimensional details

MultiJet 20 - 25

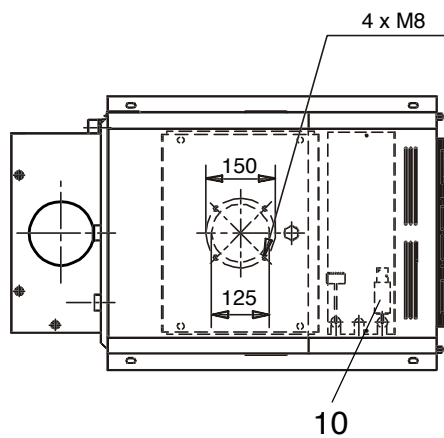
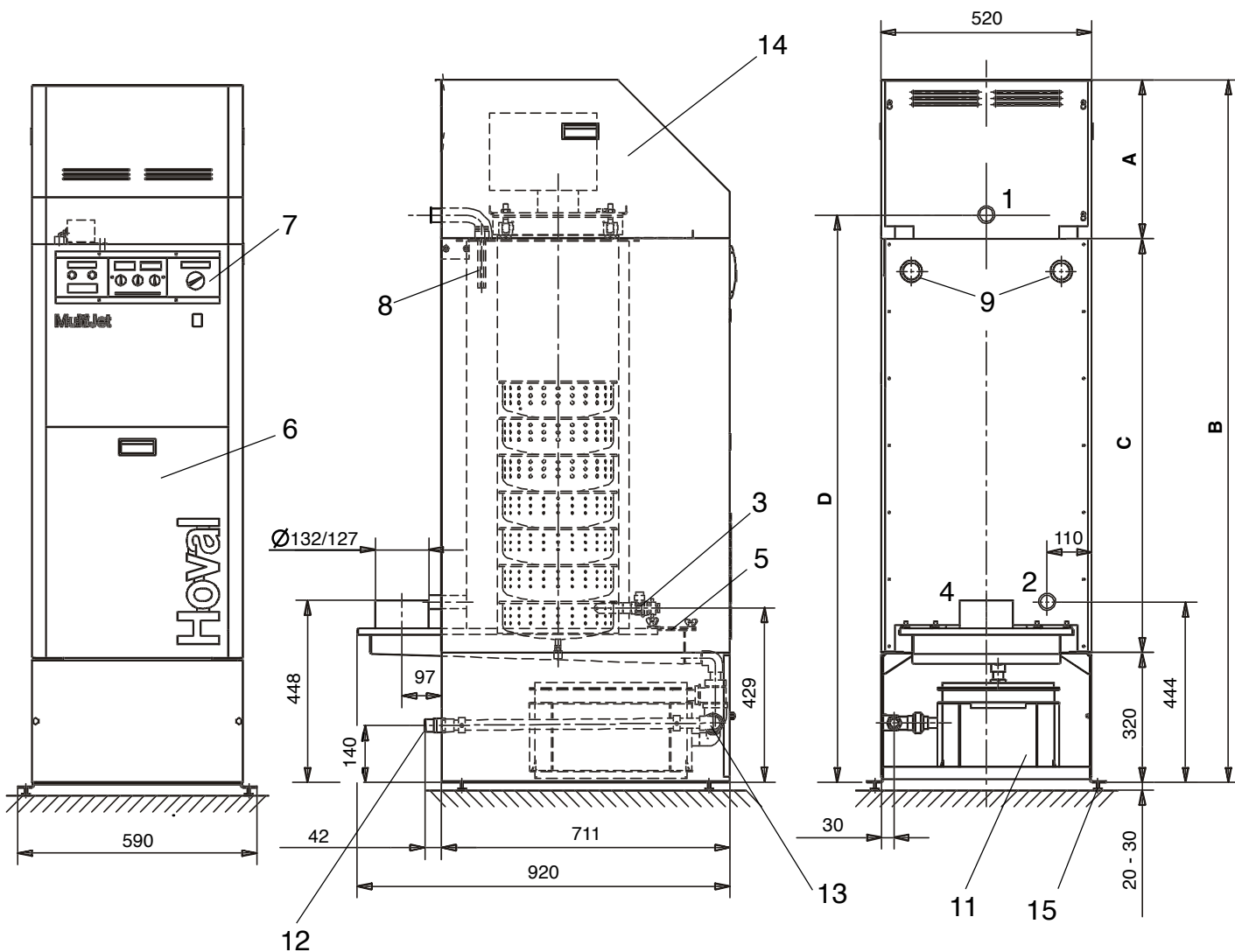

- 1. Flow R1"
- 2. Return R1"
- 3. Hydraulic drain R1/2"
- 4. Flue outlet I/D 127 mm
- 5. Explosion door
- 6. Front casing
- 7. Control panel
- 8. Thermostat pocket
- 9. Cable entry point
- 10. Burner cable
- 11. Neutralisation reservoir
- 12. Condensate connection
- 13. Condensate trap
- 14. Burner shroud
- 15. Adjustable boiler feet

MultiJet

Type	A	B	C	D
(20)	390	1730	1020	1397
(25)	390	1880	1170	1547

Space Requirements

MultiJet 16

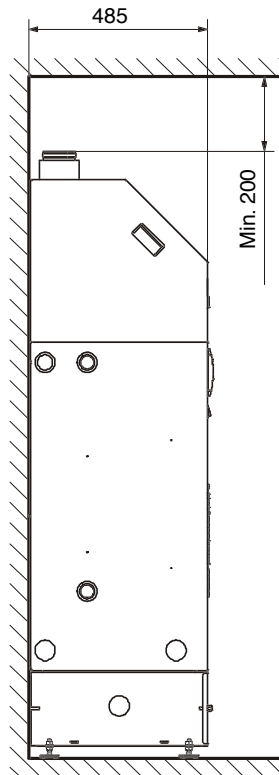
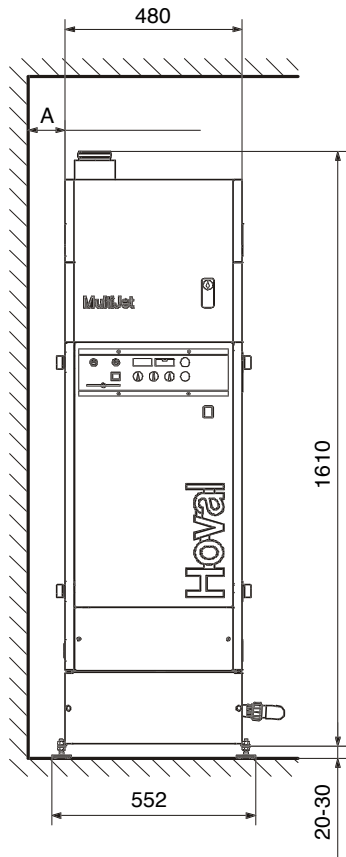

Note. Minimum clearance of 200mm is required above the boiler to give access for burner and jet insert removal.

A = 100mm access for toggle latch on shroud.

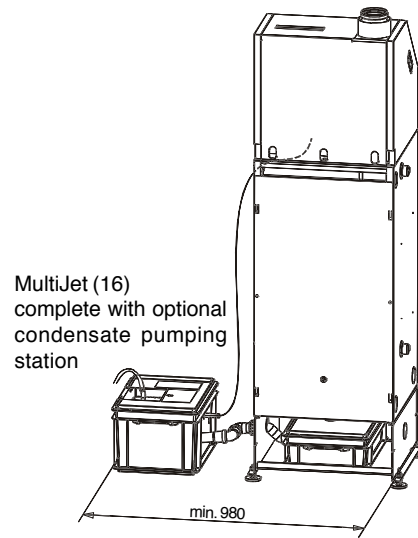

MultiJet 20 & 25

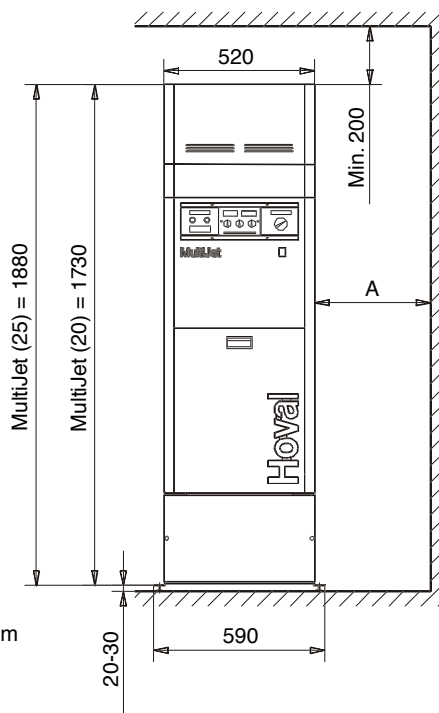
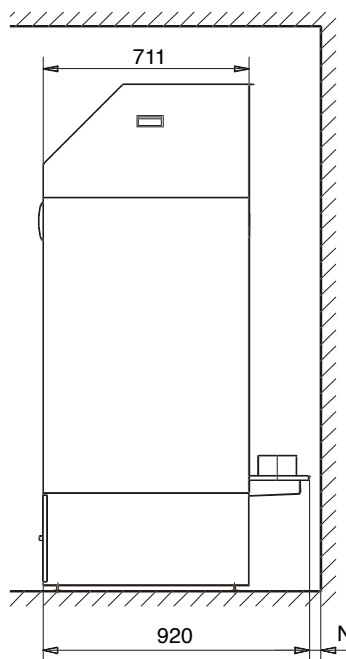

Note. Minimum clearance of 200mm is required above the boiler to give access for burner and jet insert removal.

A = 100mm access for toggle latch on shroud.

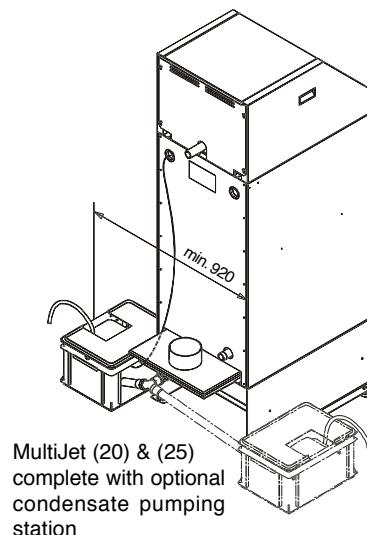

MultiJet (20) & (25) complete with optional condensate pumping station

Access for maintenance

MultiJet

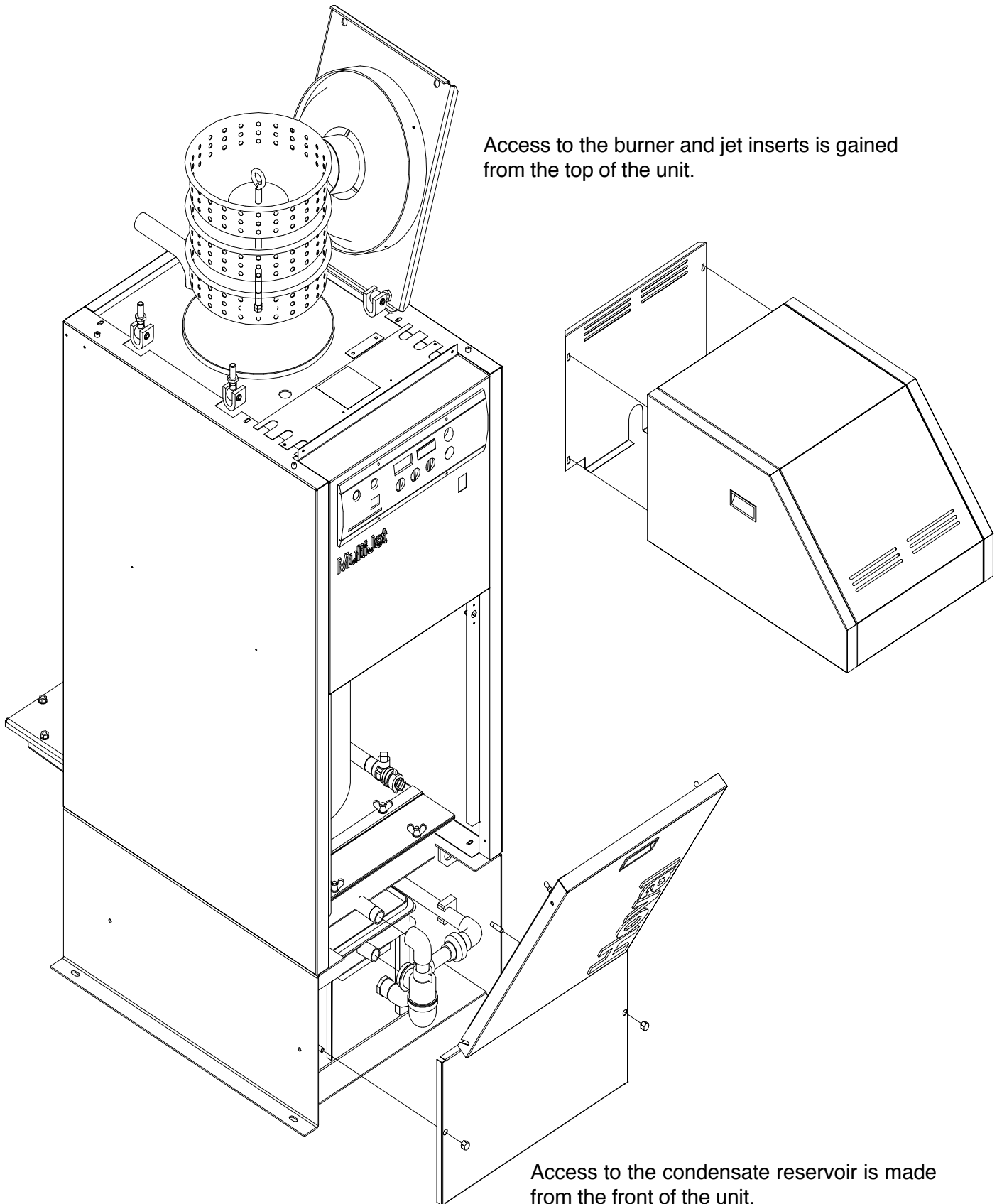

Access to the burner and jet inserts is gained from the top of the unit.

Access to the condensate reservoir is made from the front of the unit.

Typical Flue Configurations

MultiJet (16)

Hoval offer a comprehensive range of plastic flue systems.

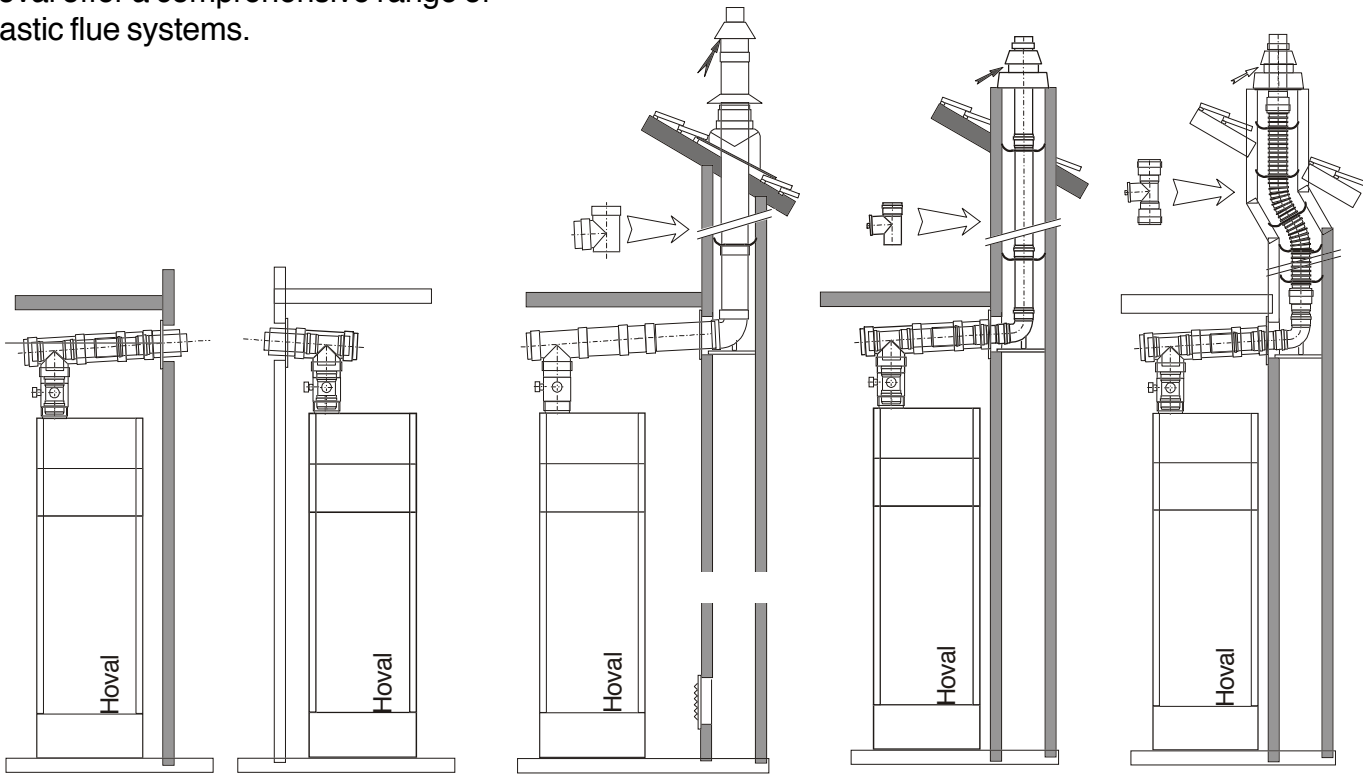

80 / 125mm concentric flue systems with 80mm single / flexible flue sections.

MultiJet (20) & (25)

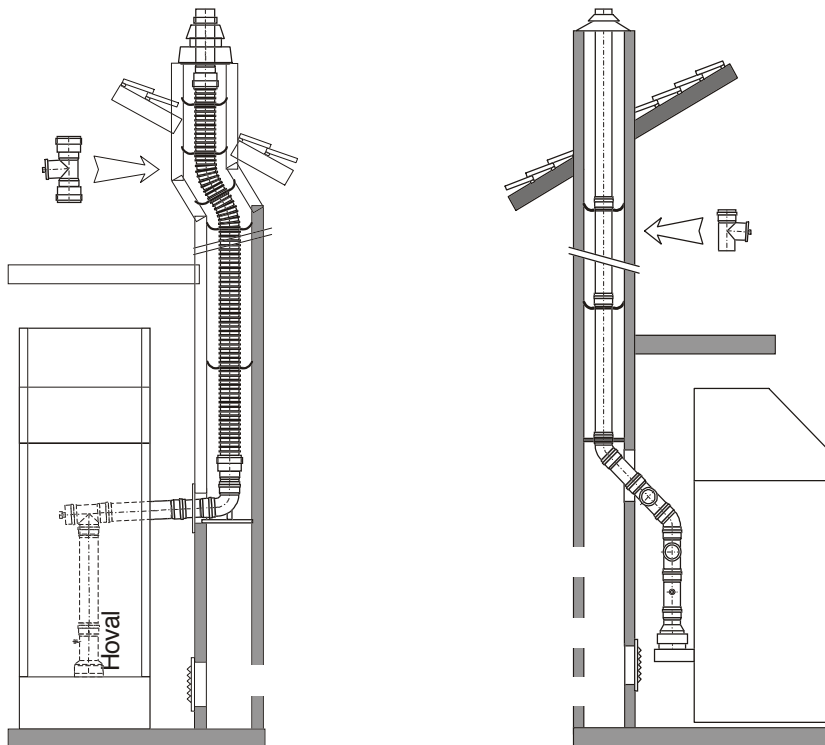

80 mm single tube flue systems including flexible flue sections

Other associated products



Mini-3

The Mini-3 boilers are the entry boiler for the Hoval pressure jet program. The smaller brother of the Uno-3 boilers, the Mini-3 offers an output range from 18kW through to 39kW. Available also as a combination boiler the Mini-3 can be supplied to provide DHW up to 300 litres storage. The design of the Mini-3 incorporates the "Bizonal Technique" which increases efficiency and life expectancy.

Hoval Ltd

Northgate
Newark
Notts
NG24 1JN
Tel: (01636) 672711
Fax: (01636) 673532
e-mail: boilersales@hoval.co.uk
Web Site: www.hoval.co.uk



Uno-3

The Uno-3 boiler couples high efficiency with low NOx emissions. These dual goals are achieved with the special 3-pass design which incorporates the unique Hoval thermolytic heat exchanger. Available as heating only units or with a calorifier as a combination unit, with ratings between 50 -280 kW and DHW up to 1110 litres per hour. A modular heatpack version is also available up to 180 kW output.



B type

The B type calorifiers are suitable for large domestic and small commercial applications. Six different sizes are available, ranging from 120 litres to 300 litres stored capacity and up to 765 litres per hour. Both direct and indirectly heated units are available. Suitable for installation in vented and unvented systems. With optional non-sacrificial anodes available on request.



PressVal Mini

The PressVal Mini is a compact wall mounted pressurisation unit which provides automatic make up and pressure for smaller sealed systems using expansion vessels up to 300 litres. Single and duplicate pump models are available complete with system high and low pressure switches and a common volt free contact. A separate system filling loop is supplied with all models.

KOOLFUEL[®]
energy for a future

Hoval